

Component List

1	Signal conductor 'Plus', pure copper	1
2	Pressure Nut PA 6.6, fibre-glass reinforced	1
3	Pressure Ring with internal damping ring	1
4	Counter Nut, PA 6.6, fibre-glass reinforced	1
5	Double Step Washer PA 6.6	1
6	Adjusting Nut Cap, Ms	1
7	Base Element Tedur ³⁾	1
8	Isolation Bowl, Makrolon ²⁾	1
9	Marking Ring	1
10	VA reinforcement (stainless steel)	1
11	Covering ring brass	1

Extent of delivery 1 – 11 mounted

Revision date 29.08.2007

¹⁾ Elastolan 95 is a registered trademark of Elastolan AB • ²⁾ Makrolon is a registered trademark of Bayer AG • ³⁾ Tedur is a registered trademark of Albis Plastic GmbH • WBT and nextgen are registered trademarks of WBT GmbH

WBT-0710 nextgen™ Pole Terminal

(International Patent EP 1 470 620)

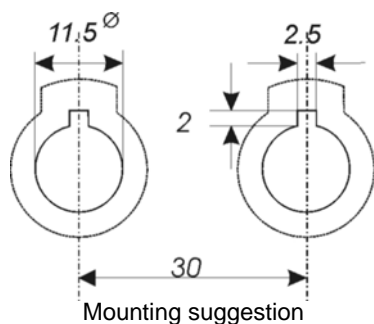

Pole terminal for cabinet wall mounting, *plug- / solder version*

1. Mechanics

- One piece, low tolerance contact element (Tol. $\pm 0.02\text{ mm}$)
- Fully insulated construction

2. Materials

- Signal Conductor (1) Pure copper
- Base Element (7) Tedur™, PA mineralized, fibre-glass reinforced
- Counter Nut (4) and Pressure Nut (2) PA, fibre-glass reinforced
- Marking Ring (9) and Double Step Washer (5) PA 6.6
- Damping Ring in (3) Elastolan 95¹⁾
- Pressure Ring (3) and Insulation Bowl (8) Makrolon²⁾
- Adjusting Nut Cap (6), Covering Ring (11) brass
- Reinforcement (10) stainless steel, non ferromagnetic

3. Surfaces:

- Signal conductor: 24-K direct gold plating, Au 0.3 μm , nickel-free, non ferromagnetic
- Adjusting Nut Cap: direct one layer gold plated with Au 0.3 μm
- All materials, including surfaces, are free from substances with ferromagnetic properties

4. Operating Characteristics (reliably observed after more than 10³ connections/disconnections)

- Permanent current $I_D \geq 30\text{ A}$
- Peak current $I_S \geq 200\text{ A}$
- Transition resistance $R_{ti} < 0.1\text{ m}\Omega$ (measured with spade connection)
- Contact resistance $R_{DCu} < 0.15\text{ m}\Omega$ (measured with spade connection)
- Insulation resistance $R_{iso} > 10^{10}\Omega$

5. Connection Options

- solder (optimal for cable up to 4 mm²/11 AWG)
- plug (for 6.3 mm flat push-on cable shoe)

6. Mounting

- Chassis drill hole $\varnothing 11.5^{+0.2}\text{ mm}$ with slot 2.5x2 mm for twist prevention (see drilling scheme)
- For wall thickness from 0.9 to 6.5 mm. With puzzle plate (s. picture on left) WBT-9410: 0.9 to 4.5 mm
- Recommended distance between two terminal centres: 30 mm
- Recommended tightening torque for the counter nut (4): 0.8 Nm



WBT-0710 Cu
RoHS compliant